



SPAWER

Les pompes à chaleur pour spa

POOLEX
ICE SPA



Installation and user manual

Automated Environmental Systems
Unit B, Anglian Lane,
Bury St. Edmunds,
Suffolk,
IP32 6SR
01284 658770
sales@automatedenvironmentalsystems.co.uk

ACKNOWLEDGEMENTS

Dear customer,

Thank you for your purchase and your trust in our products.

Our products are the result of years of research in the design and manufacture of heat pumps for pools. Our goal is to deliver high-quality products with exceptional performance.

We took great care to put together this manual so you can get the most out of your Poolex heat pump.

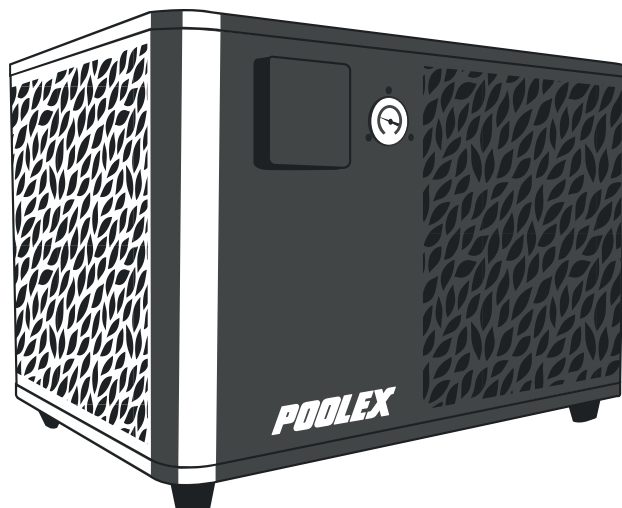



PLEASE READ CAREFULLY



These installation instructions form an integral part of the product.
They must be provided to the installer and kept in a safe place by the user.
If you lose this manual, please visit our website:

www.poolex.fr

The indications and warnings contained in this manual should be carefully read and understood as they provide important information regarding the safe handling and operation of the heat pump. Keep this manual handy for future reference.

Installation must be performed by a qualified professional in accordance with regulations in force and the manufacturer's instructions. Errors made during installation can cause physical injuries to people and animals, as well as mechanical damage for which the manufacturer shall not be held liable.

After unpacking the heat pump, please check the contents for any signs of damage.

Before plugging in the heat pump, ensure that the instructions provided in this manual are compatible with the actual installation conditions and do not exceed the maximum authorised limits for the product in question.

In the event of a defect and/or malfunction of the heat pump, electrical power must be shut off and no attempts to repair the fault should be made.

Repairs must be carried out by an authorised technician using original spare parts. Non-compliance with the aforementioned clauses can negatively impact the safe operation of the heat pump.

In order to guarantee the efficiency and ensure the proper functioning of the heat pump, it must be regularly maintained in accordance with the instructions provided.

In the event the heat pump is sold or transferred to a third party, please ensure that all technical documentation is given to the new owner alongside the equipment.

This heat pump has been designed to only heat the water of a swimming pool. Any other use is considered inappropriate, incorrect and potentially dangerous.

All contractual and extra-contractual liability on the part of the manufacturer / distributor shall be considered null and void in the event of damage caused by errors in installation or operation, or due to non-compliance with the instructions provided in this manual, or the standards in force for the installation of equipment discussed in this document.

CONTENTS

1. General information	4
1.1 General terms and conditions of delivery	4
1.2 Safety instructions	4
1.3 Water treatment	5
2. Description	6
2.1 Operating limits	6
2.2 Package contents	6
2.3 General characteristics	6
2.4 Technical characteristics	7
2.5 Product dimensions	8
2.6 Exploded view	9
3. Installation	10
3.1 Location	10
3.2 Installation diagram	11
3.3 Hydraulic connection	11
3.4 Electrical connection	11
3.5 Operation	12
4. Use of control panel	13
4.1 Control panel	13
4.2 Temperature setting	13
4.3 Choice of operating mode	14
4.4 Settings menu	15
1. Activate wifi	15
2. Modify user settings	16
3. Modify factory settings (not recommended)	17
4. Set heater or circulation pump (optional)	18
5. Change temperature unit	18
6. Set time and date	18
7. Set display brightness	18
8. Reset settings	18
4.5 Consult heat pump data	19
1. Temperature readings	19
2. System values	19
3. Error history	20
4. Hardware and software versions	20
5. Use of optional control relays	21
5.1 Using the SPA heater control relay (optional)	21
5.2 Using the circulation pump control relay (optional)	22
6. Use via mobile application	23
6.1 Downloading & installing the application «Smart Life»	23
6.2 Setting up the application	24
6.3 Pairing the heat pump	26
6.4 Controlling	27
1. User interface	27
2. Heat pump operating mode selector	27
3. About the settings	28
4. Setting up the heat pump operating range	28
7. Maintenance and Repairs	29
7.1 Maintenance, servicing and winterizing	29
7.2 Checking refrigerant pressure	29
7.3 Breakdown and faults	30
8. Warranty	32
8.1 General terms and conditions of warranty	32

1. GENERAL INFORMATION

1.1 General terms and conditions of delivery

All products and packaging, even those delivered carriage paid, travel at the risk of the recipient. Persons responsible for accepting delivery of the device must perform a visual inspection to make a note of any damage that may have occurred during transportation (refrigeration circuit, casing, electric box, frame). Any damage occurring during transportation must be noted by the recipient on the delivery receipt of the carrier, and confirmed by registered post sent to the carrier within 48 hours.



The device must be stored and transported upright at all times, on a pallet, and in its original packaging. If the device has been transported in a horizontal position, please wait at least 24 hours prior to connecting it.

1.2 Safety instructions



WARNING: Please read carefully all safety instructions before using the device. As the instructions noted in this document are essential to your safety, please respect them carefully.

Installation and maintenance

Only a qualified person may undertake installation, start-up, servicing and repairs, in compliance with current standards.

Before operating or undertaking any work on the device (installation, start-up, use, servicing), the person responsible must be aware of all the instructions in the heat pump's installation manual as well as the technical specifications.

Under no circumstances install the equipment close to a source of heat, combustible materials or a building's air intake.

If installation is not in a location with restricted access, a heat pump protective grille must be fitted.

To avoid severe burns, do not walk on pipework during installation, repairs or maintenance.

To avoid severe burns, prior to any work on the refrigerant system, turn off the heat pump and wait several minutes before placing temperature and pressure sensors.

Check the refrigerant level when servicing the heat pump.

Check that the high and low pressure switches are correctly connected to the refrigerant system and that they turn off the electrical circuit if tripped during the equipment's annual leakage inspection.

Check that there is no trace of corrosion or oil stains around the refrigerant components.

1. GENERAL INFORMATION

When in use

Do not touch the vent during operation due to the risk of serious injury.

Do not leave the heat pump within reach of children due to the risk of injury caused by the heat exchanger fins.

Never start the equipment if there is no water in the pool or if the circulating pump is stopped.

Check the water flow rate every month and clean the filter if necessary.

When cleaning

1. Switch off the power supply to the device.
2. Close the water inlet and outlet valves.
3. Do not place anything in the openings of the water or air inlets/outlets.
4. Do not spray the appliance with excessive amounts of water.

During repairs

Carry out work on the refrigerant system in accordance with current safety regulations.

Brazing should be performed by a qualified welder.

When replacing a defective refrigerant component, use only parts certified by our technical department.

When replacing pipework, only copper pipes conforming to Standard NF EN12735-1 may be used for repairs.

1.3 Water treatment

Poolex heat pumps for swimming pools can be used with all types of water treatment systems.

Nevertheless, it is essential that the treatment system (chlorine, pH, bromine and/or salt chlorinator metering pumps) is installed after the heat pump in the hydraulic circuit.

To avoid any deterioration to the heat pump, the water's pH must be maintained between 6.8 and 7.8.

2. DESCRIPTION

2.1 Operating limits

For the heat pump to operate normally, the ambient air temperature must be between -25°C and 43°C.

Your hot tub must be correctly insulated to enable the ICE SPA heat pump to function in an optimal way.



The tub must be insulated.



The piping must be insulated.



The hot tub must be equipped with an insulating cover.

2.2 Package contents

At reception, please check that your package contains the following:



A Poolex ICE SPA heat pump



2 hydraulic connections 1" (inch) to connections 32/38 mm



2 stainless steel clamps



2 lifting straps



1 condensate drain kit



1 extension cable for remote control panel (10m)



1 10mA residual current circuit breaker (RCD) integrated into electrical socket



4 anti-vibration pads (mounted directly on the heat pump)



This installation and user manual

2.3 General characteristics

A Poolex heat pump has the following features:

- ▶ High performance with up to 80% energy savings compared to a conventional heating system.
- ▶ Clean, efficient and environmentally friendly R32 refrigerant.
- ▶ Reliable high output leading brand compressor.
- ▶ Wide hydrophilic aluminum evaporator for use at low temperatures.
- ▶ User-friendly intuitive control panel.
- ▶ Heavy duty shell, anti-UV treated and easy to maintain.
- ▶ CE certification.

2. DESCRIPTION

2.4 Technical characteristics

		ICE SPA
Air ⁽¹⁾ 26°C Water ⁽²⁾ 26°C	Heating power (kW)	5,38~2,50
	Consumption (kW)	1,01~0,18
	COP (Coeff. of performance)	5,33~13,89
Air ⁽¹⁾ 15°C Water ⁽²⁾ 26°C	Heating power (kW)	4,18~2,01
	Consumption (kW)	0,92~0,27
	COP (Coeff. of performance)	4,54~7,44
Air ⁽¹⁾ 15°C Water ⁽²⁾ 38°C	Heating power (kW)	3,70~1,81
	Consumption (kW)	1,2~0,3
	COP (Coeff. of performance)	3,01~5,6
Air ⁽¹⁾ -10°C Water ⁽²⁾ 38°C	Heating power (kW)	2,95~1,52
	Consumption (kW)	1,6~0,45
	COP (Coeff. of performance)	1,85~3,38
Air ⁽¹⁾ 35°C Water ⁽²⁾ 27°C	Cooling capacity (kW)	3,38~2,06
	Consumption (kW)	0,97~0,41
	EER	3,38~5,02
Power supply	Single phase 220-240V ~ 50Hz	
Maximum power (kW)	1,8	
Maximum current (A)	7,99	
Heating temperature range	15°C ~ 40°C	
Cooling temperature range	7 °C ~ 35 °C	
Operating range	-25°C ~ 43°C	
Unit dimensions L x W x H (mm)	600*443*423	
Unit weight (kg)	40	
Sound pressure level at 1m (dBA)	< 55	
Sound pressure level at 4m (dBA)	< 40	
Sound pressure level at 10m (dBA) ⁽³⁾	< 32	
Hydraulic connections (mm)	PVC 32/38 mm	
Heat exchanger	Titanium heating coil	
Min. water flow rate (m³/h)	2,31	
Compressor type	Rotary	
Refrigerant	R32	
Refrigerant volume (g)	430	
Maximum pressure (MPa)	4,3	
Protection rating	IPX4	
Load loss (mCE)	0,8	
Control panel	Digital-display control panel	
Operating modes	Heating/Cooling/Auto	

The technical specifications of our heat pumps are provided for information purposes only. We reserve the right to make changes without prior notice.

¹ Ambient air temperature

² Initial water temperature

³ Noise level at a distance of 10 m in accordance with international standards EN ISO 3741 and EN ISO 354

2. DESCRIPTION

2.5 Product dimensions

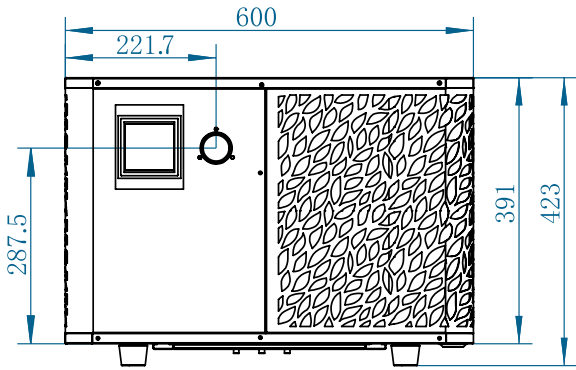

Dimensions in mm

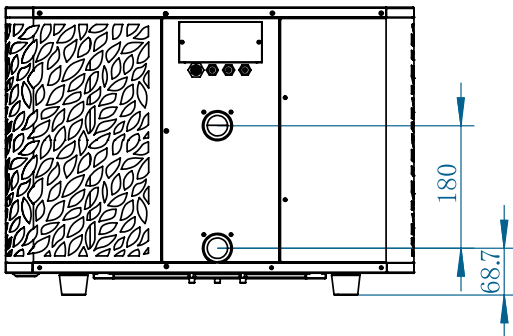
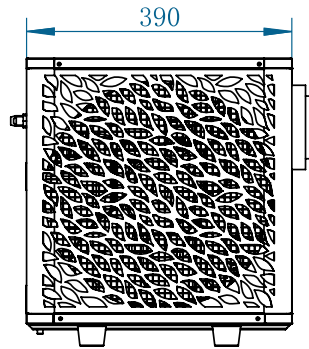
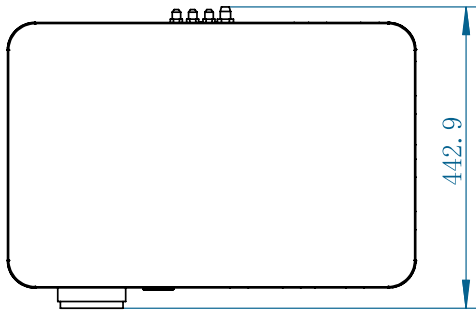

2. DESCRIPTION

2.6 Exploded view

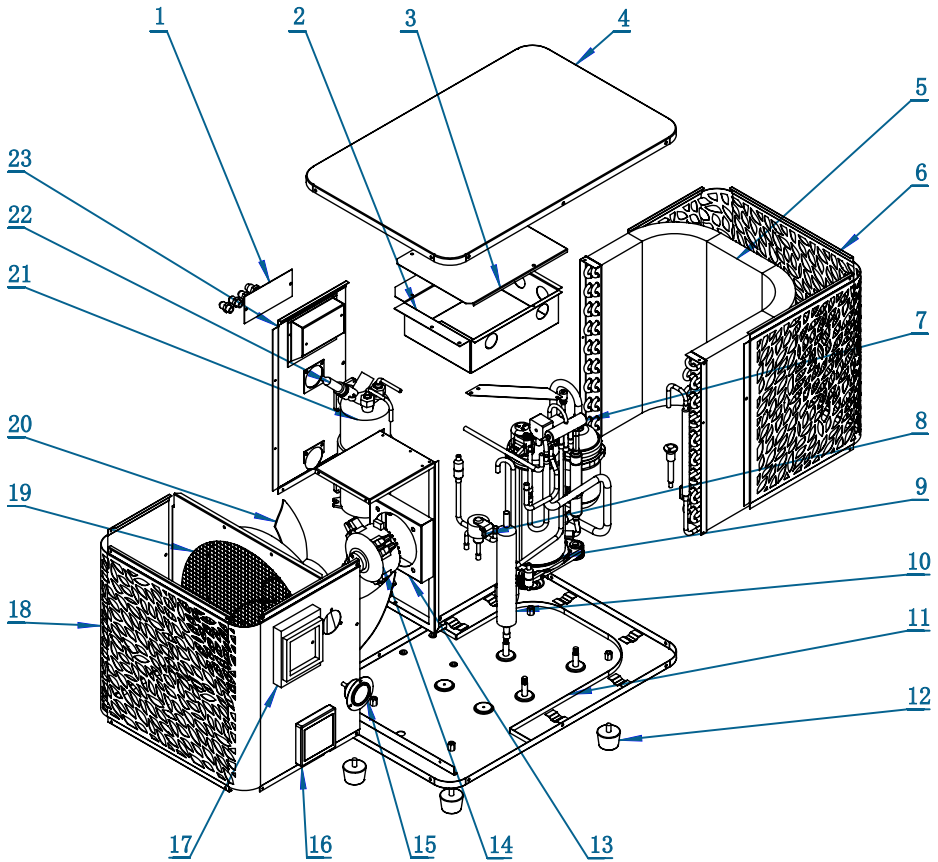

- | | |
|-------------------------------|-----------------------------|
| 1. Terminal block | 13. Fan motor support |
| 2. Electrical box | 14. Fan motor |
| 3. Electrical box cover | 15. Manometer |
| 4. Top cover | 16. Control panel |
| 5. Evaporator | 17. Control panel cover |
| 6. Back panel | 18. Front panel |
| 7. 4-way valve | 19. Wind deflector |
| 8. Electrical expansive valve | 20. Fan blade |
| 9. Compressor | 21. Titanium heat exchanger |
| 10. EVI tank | 22. Water flow switch |
| 11. Base plate | 23. Left side panel |
| 12. Rubber feet | |

3. INSTALLATION

To install the heat pump the hydraulic circuit and the power need to be connected.

3.1 Location

Standard NF C 15-100 recommends installing the heat pump at least 2.5 meters from the pool. However, thanks to the differential circuit breaker, you can also choose to install it closer: Leave at least 1.50 m in front of the heat pump and 30 cm of empty space to the sides and rear of the heat pump.

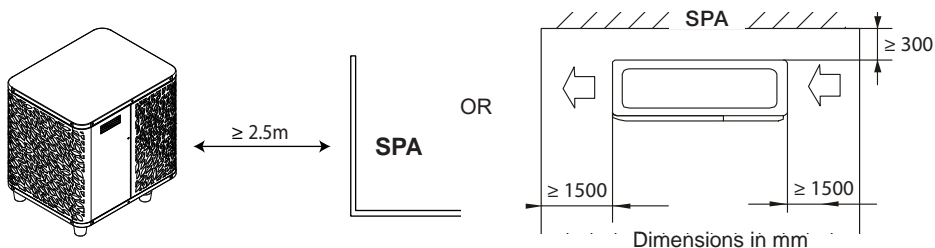

- Do not place anything within 1.5m of the front of the heat pump.**
- Do not place any obstacles on top or in front of the device!**
- Do not use the heat pump as a step to access the spa.**
- Do not step on the heat pump.**

Please respect the following rules when choosing the heat pump's installation location

1. The location must be easily accessible for optimal operation and maintenance.
2. The device must be installed on the ground, ideally on a level concrete slab. Ensure that the ground is sufficiently stable and it can support the weight of the device.
3. Check that there is enough air flow, that the air exhaust is not directed towards the windows of neighbouring buildings, and that exhaust air cannot return to the intake. In addition, ensure that there is enough space around the device to perform servicing and maintenance.
4. The device must not be installed in locations susceptible of being exposed to oil, flammable gas, corrosive agents, sulphur compounds, or near high frequency devices.
5. Do not install the device near to roads or footpaths to avoid mud splattering.
6. To avoid disturbing neighbours, make sure to install the device facing away from areas sensitive to noise.
7. Keep out of the reach of children insofar as possible.

3. INSTALLATION

3.2 Installation diagram

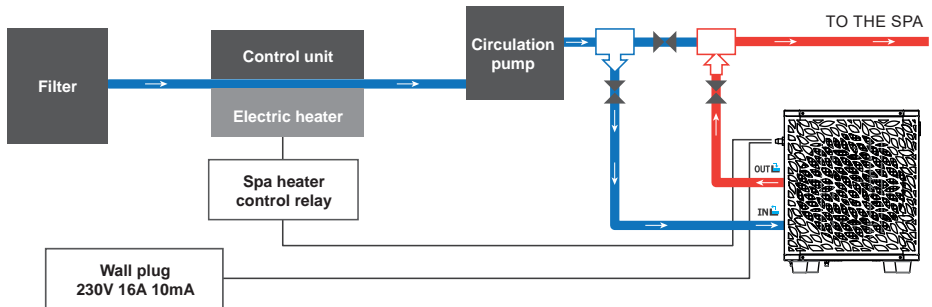

The filter located upstream of the heat pump must be regularly cleared so that the water in the system is clean, thus avoiding the operational problems associated with dirt or clogging in the filter.

3.3 Hydraulic connection

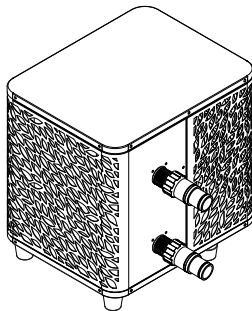

Step 1

Screw the connectors for heat pump

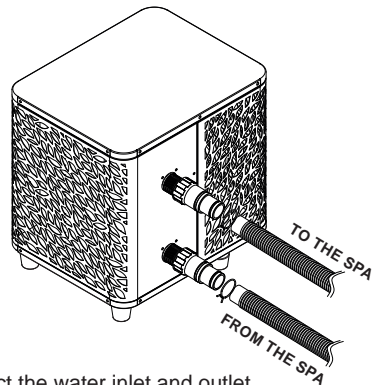

Step 2

Connect the water inlet and outlet

3.4 Electrical connection

Pump's power plug integrates a 10mA differential circuit breaker.

Regularly test the correct operation. In the event of successive triggering or doubts contact the after-sales service.

Before plugging in your heat pump, please ensure the electrical socket is well protected, properly grounded and protected from rain as well as water projections.

Press the RESET button to start the ICE SPA heat pump. The power indicator lights up in red: the heat pump is on.

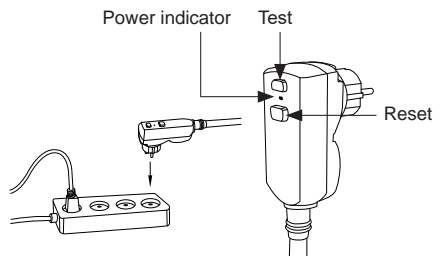

3. INSTALLATION







3.5 Operation

Use conditions

For the heat pump to operate normally, the ambient air temperature must be between -25°C and 43°C .

Advance notice

Prior to starting the heat pump, please:

-  Check that the equipment is secure and stable.
-  Check that the gauge indicates a pressure greater than 80 psi.
-  Check that the electrical wiring is properly connected to the terminals.
-  Check the earthing connections.
-  Check that the hydraulic connections are tight and that there is no leakage of water.
-  Check that the water is circulating correctly in the heat pump and that the flow rate is adequate
-  Remove any object that is not required around the equipment and all tools.

Operation

1. Connect the power supply to the device.
2. Start the filtration pump.
3. Activate the device's electrical supply protection (differential switch situated on the power cable).
4. Start the heat pump.
5. Select the desired temperature using one of the modes appearing on the control panel.
6. The heat pump's compressor will start shortly after.

And you just need to wait for the target temperature to be reached.



WARNING: Under normal conditions, a suitable heat pump can heat up the tub water by 1°C to 2°C per hour. It is therefore normal that you do not feel any difference in temperature at the outlet level when the heat pump is on.

A heated tub must be covered and insulated to avoid any heat loss.

Good to know: restart after power failure

After a power failure or a usual interruption, turn the power back on, the system is on sleep mode. Restart the differential plus and switch on the heat pump.

4. USE OF CONTROL PANEL

4.1 Control panel

Familiarize with the display before you start.

The control panel can be moved using the extension lead.

Use the extension cord to store the control panel away from rain and light. Shade will ensure better visibility of the screen. Under no circumstances should the control panel be exposed to moisture.

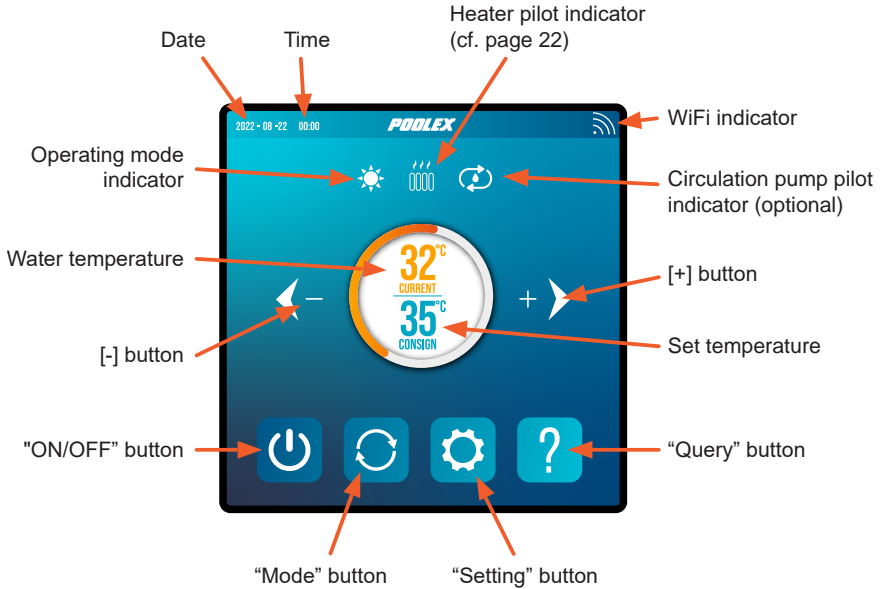

4.2 Temperature setting



Before use, ensure that the filtration pump is working and that water is circulating through the heat pump.

The water temperature appears in orange, except when you set your target temperature, which then appears in orange. Use the [+] and [-] buttons to adjust the set temperature. When you press either of these buttons, they also turn orange, as shown in the image opposite.

4. USE OF CONTROL PANEL

4.3 Choice of operating mode

The selected operating mode appears here as an icon.



Heating mode

Select heating mode if you want to heat up the tub water with the heat pump.

Cooling mode



Select heating mode if you want to cool the tub water with the heat pump.

Automatic mode

Select automatic mode if you want the heat pump to switch modes intelligently around the set temperature.

By default, the heat pump is in heating mode. The activated mode symbol appears on the left above the temperatures and in yellow in the operating modes menu.

To change the operating mode, when the heat pump is on:

- Press the button , the heat pump will then switch to cooling.
- Press the button , the heat pump will then switch to automatic.
- Press the button , the heat pump will then switch heating.

The different modes thus form a cycle:

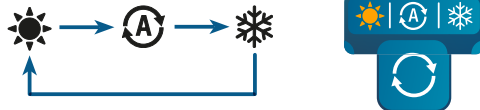

Good to know:







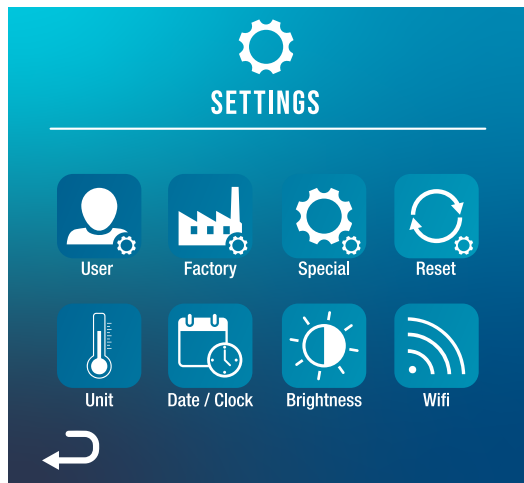

The heat pump can take several minutes to change operating mode in order to preserve the refrigerant fluid.

4. USE OF CONTROL PANEL

4.4 Settings menu

From the Home screen, press the "Settings" button  to access this menu.



Button	Function
	Modify user settings
	Change temperature unit
	Modify factory settings
	Set time and date
	Set heater or circulation pump (optional)
	Set display brightness
	Activate wifi and pair your heat pump
	Reset settings

Remarque : le bouton "Unit" n'est pas fonctionnel dans cet édition du produit. Merci de l'ignorer.



Previous page



Next page



Confirm



Confirm Back

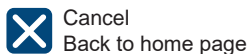

Cancel
Back to home page

1. Activate wifi

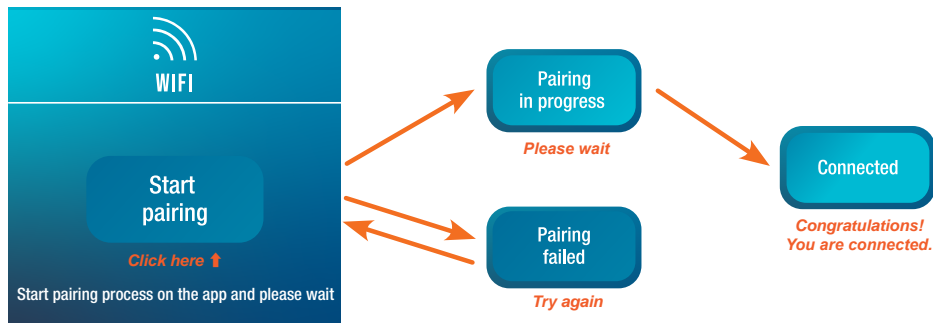

In the "Settings" menu, use the "Wifi" button  to access the pairing interface..



Pairing allows you to control your heat pump from a remote control application. This is described in more detail in section 6, "6. Use via mobile application", page 23.

4. USE OF CONTROL PANEL

2. Modify user settings

In the "Settings" menu, use the "User" button  to access the user settings interface. Then click on the input box  of the parameter you wish to modify.

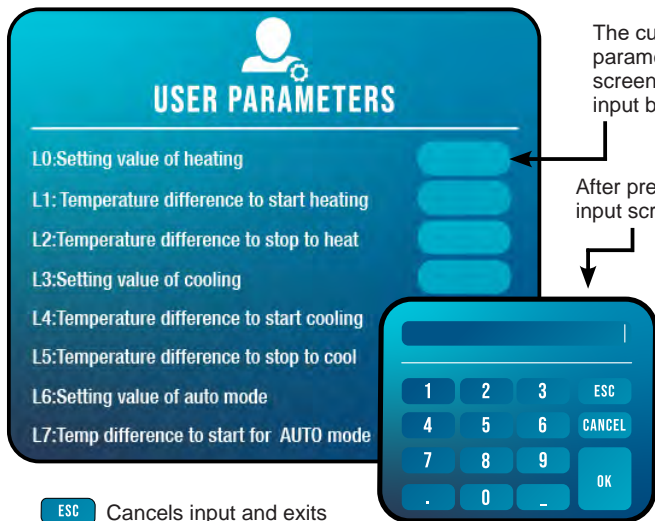

The current value of each parameter is displayed on this screen in the corresponding input boxes.

After pressing the input box, the input screen appears.

Enter the value of your choice, then press "OK".

The chosen value must be available within the parameter setting range (see below), otherwise your choice will not be saved.

ESC Cancels input and exits

CANCEL Clears the last digit or symbol entered

List of user settings

N°	Description	Adjustment range	Default V.
L0	Setting value of heating	15°C~40°C	38°C
L1	Temperature difference to start heating	1°C~5°C	3°C
L2	Temperature difference to stop heating	0°C~5°C	1°C
L3	Setting value of cooling	7°C~35°C	26°C
L4	Temperature difference to start cooling	1°C~5°C	2°C
L5	Temperature difference to stop cooling	0°C~5°C	1°C
L6	Setting value of auto mode	7°C~40°C	38°C
L7	Temperature difference to start for AUTO mode	1°C~5°C	2°C
L8	Circulation pump relay activation	0 (deactivated) /1 (activated)	0
L9	Water pump startup interval when the machine standby	30-90 min	60 min
L10	E-heater relay activation	0 (deactivated) /1 (activated)	0
L11	Ambient temperature to start the e-heater	0°C~25°C	5°C
L12	Temperature difference to start the e-heater automatically	1°C~5°C	5°C
L13	Temperature difference to start the e-heater manually	1°C~5°C	2°C

4. USE OF CONTROL PANEL

3. Modify factory settings (not recommended)

In the "Settings" menu, use the "Factory" button  to access the factory settings interface. You will be prompted for a password. **Contact your after-sales service: changing the factory settings without authorisation from the after-sales service will invalidate the warranty.**



WARNING : This operation is used to assist servicing and future repairs. The default settings should only be modified by an experienced professional person.
Unauthorized modification of factory settings may invalidate the warranty.

The current value of each setting is displayed on the screen in the corresponding input boxes.

If you have been authorised to change a setting, select the setting and press the corresponding input box.  The input screen appears. Enter the desired value and press "OK".

The chosen value must be available within the parameter's setting range (see "Factory settings list", below), otherwise your choice will not be saved.

Factory settings list

N°	Description	Adjustment range	Default V.
H0	Cumulative heating run time set value	1~120 min	45min
H1	Defrosting run sets maximum defrosting time	1~25 min	12min
H2	Temperature to exit defrosting	1°C~25°C	12°C
H3	Temperature enter defrosting temperature 1	-20°C~20°C	-1°C
H4	Temperature enter defrosting temperature 2	-20°C~20°C	-2°C
H5	Temperature enter defrosting temperature 3	-20°C~20°C	-4°C
H6	Temperature enter defrosting temperature 4	-20°C~20°C	-6°C
H7	Temperature difference to enter defrosting 1	-20°C~20°C	-7°C
H8	Temperature difference to enter defrosting 2	-20°C~20°C	-8°C
H9	Temperature difference to enter defrosting 3	-20°C~20°C	-8°C
H10	Temperature difference to enter defrosting 4	-20°C~20°C	-8°C
H11	Temperature difference to enter defrosting 5	-20°C~20°C	-8°C
P0	The maximum compressor frequency when heating	30~100 Hz	100 Hz
P1	The minimum compressor frequency when heating	30~60 Hz	30 Hz
P2	The maximum compressor frequency when cooling	30~100 Hz	70 Hz
P3	The minimum compressor frequency when cooling	30~60 Hz	30 Hz
P4	The maximum opening of main EEV	80~480 P	480 P
P5	The minimum opening of main EEV	45~480 P	60 P
P24	Maximum set temperature when heating	30°C~60°C	40°C
P25	Minimum set temperature when heating	5°C~30°C	15°C
P26	Maximum set temperature when cooling	15°C~30°C	35°C
P27	Minimum set temperature when cooling	5°C~15°C	7°C

4. USE OF CONTROL PANEL

4. Set heater or circulation pump (optional)

In the "Settings" menu, use the "Special" button  to access the following interface:

<input type="checkbox"/> Heater manual mode	Switch e-heater relay to manual mode
<input type="checkbox"/> Pump manual mode	Switch circulation pump relay to manual mode

Parameters L8 and L10 must be enabled to use this menu.

- If L8 = 0, the circulation pump relay cannot be activated manually.
- If L10 = 0, the heater relay cannot be activated manually.

See "Modify user settings", page 16, to enable or disable these options.

The use of these two relays is described in more detail in "5. Use of optional control relays", page 21.

5. Set time and date

In the "Settings" menu, use the "Date / Clock" button  to change the date and/or time displayed on the screen. Date and time are also useful for error history reliability (see page 21).

The value entered in each box must be possible to be taken into account. The date format is: month - day - year.

A value greater than 12 cannot be entered in the month box.



6. Set display brightness

In the "Settings" menu, use the "Brightness" button  to modify screen brightness.



Slide the slider to the left to decrease brightness, or to the right to increase it.

Tip: Use the extension cable to store the control panel away from light. The shade will ensure better visibility of the screen.

7. Reset settings

In the "Settings" menu, use the "Reset" button  to reset the parameters.

A code is required. Contact the After Sales Service.

You will be asked to confirm your wish to reset the settings.







When the parameters are reset, the message "Initialization succeeded" is displayed.

4. USE OF CONTROL PANEL

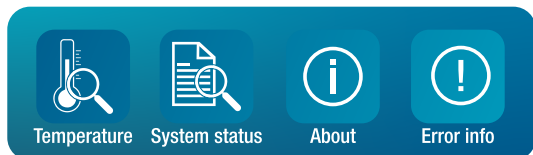
4.5 Consult heat pump data

From the home screen, press the "Query" button  to access this menu.



Button	Function
	Temperature readings
	System values
	Error history
	Hardware and software versions

1. Temperature readings

In the "Query" menu, use the "Temperature" button  to view the following temperature readings.

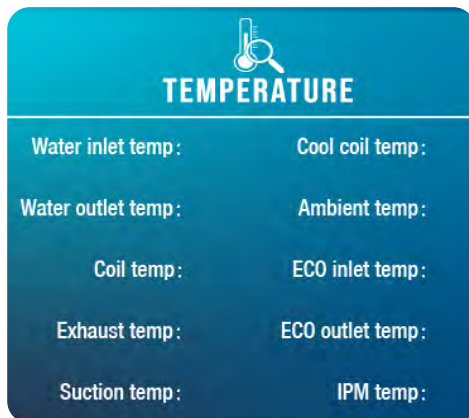

2. System values

In the "Query" menu, use the "System status" button  to view the following :

- system values:

- Target frequency
- Compression frequency
- Alternating voltage
- Alternating current
- DC voltage
- Compressor current
- Fan speed
- Main valve
- Auxiliary valve

- and states (on/off):

- Four-way valve
- Pump
- Auxiliary heater
- Crankshaft heater
- Chassis heater
- Oil return
- Defrost

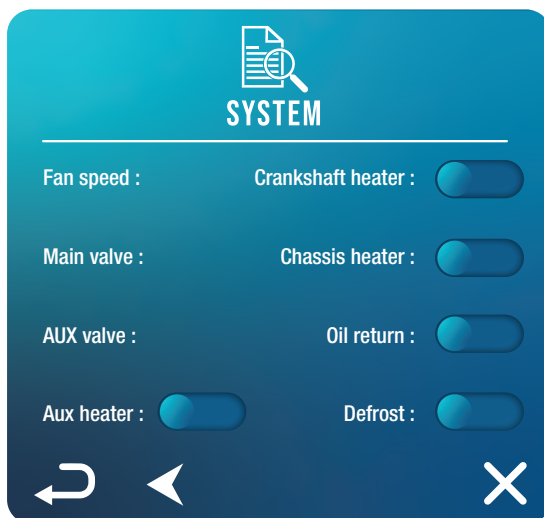

4. USE OF CONTROL PANEL

3. Error history

In the "Query" menu, use the "Error info" button  to consult the history of errors encountered.

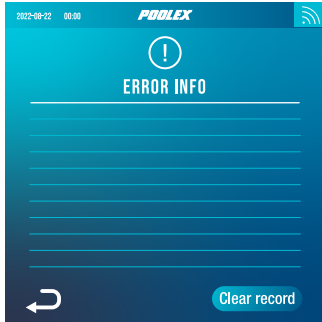

This screen displays a list of previously encountered errors. Each line shows an error in the format "date + time + error code".

In addition, when an error is encountered, it is displayed in a banner at the top of the home screen.

The banner looks like this:



The history can be deleted, for example if you resell your heat pump. To do this, click on "Clear record".

4. Hardware and software versions

In the "Query" menu, use the "About" button  to view information about:

- wire controller software version
- wire controller hardware version
- master controller software version
- master controller hardware version



5. USE OF OPTIONAL CONTROL RELAYS

5.1 Using the SPA heater control relay (optional)

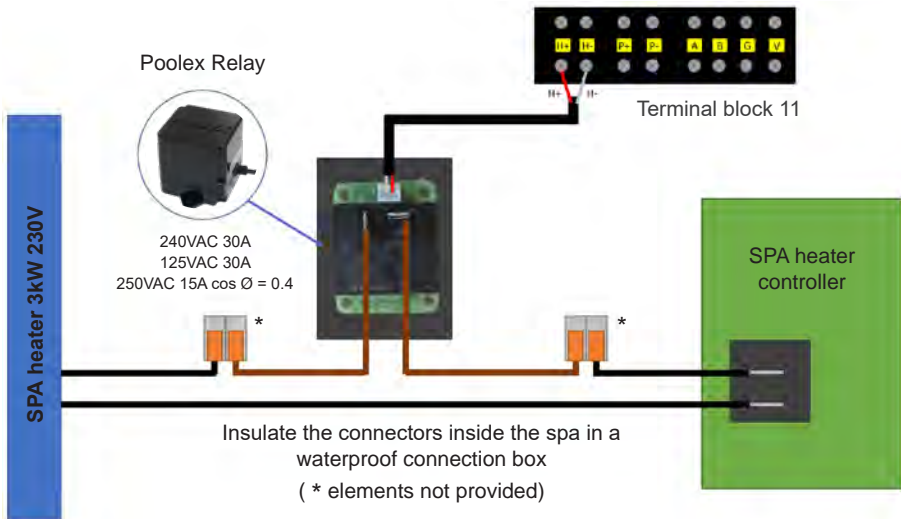

The SPA heater SPAWER driver system consists of a power relay (230V50Hz / 30A) which plugs into the heater phase wire (between the SPA heater controller output and the heater itself).

This relay is controlled by the heat pump control box either automatically or manually (boost).

As such, for the system to work properly, **it is imperative to set the desired temperature of the SPA water to the maximum on the SPA control screen and to programme the filtration time.** In this way, the actual temperature setting will now be done on the heat pump or via the smartphone application.

- **In automatic spa heater mode:** When weather conditions become difficult for the heat pump (L11 setting: outside temperature below a specified temperature, adjustable from 0 to 25°C) and the desired bathing temperature is higher than the measured water temperature (L12 setting, adjustable from 1 to 10°C), the heater control relay is triggered. Thus the heating uses the electric heater of the SPA in addition to the heat pump in order to reach the desired temperature.

- **In manual spa heater mode:** Regardless of the weather conditions, as soon as the deviation between setpoint and measured temperature exceeds the set deviation (L13 setting, adjustable from 1 to 10°C), the relay is triggered. Thus the heating uses the electric heater of the SPA in addition to the heat pump in order to reach the desired temperature.

To use this relay:

Setting the L10 setting = 1 to start the control (see "Modify user settings", page 16).

5. USE OF OPTIONAL CONTROL RELAYS

5.2 Using the circulation pump control relay (optional)

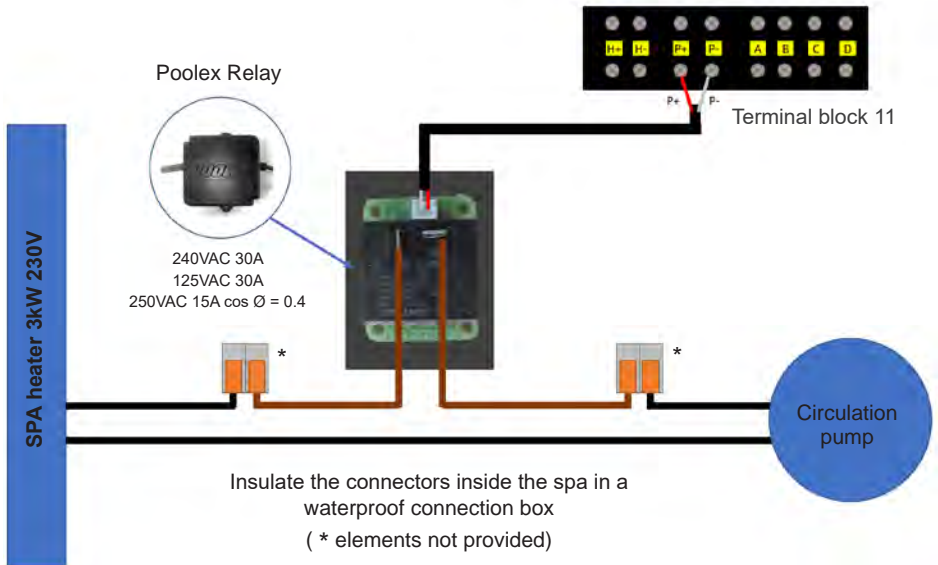

This relay is controlled by the heat pump control box either automatically or manually.

As such, for the system to function correctly, **it is imperative to have a circulation pump which minimum flow ranges from 1.2 m³/h to 3 m³/h** (to be determined according to the pump selected).

In automatic mode: The relay activates itself every 60 minutes (timing adjustable between 30 and 90 minutes, L9 setting) to control the circulation pump whilst temperature is being verified. If needed, the controller starts the heat pump to reach the target temperature while the pump relay remains active up until the target temperature is reached, then will start its verification cycle every 60 minutes (timing adjustable between 30 and 90 minutes, L9 setting).

In manual mode: The pump relay will always be active and the pump will function 24/7.

To use this relay:

Setting the **L8** setting = 1 to start the control (see "Modify user settings", page 16).

Adjusting verification time intervals, L9 setting, if necessary (adjustable from 30 to 90 minutes).

6. USE VIA MOBILE APPLICATION

6.1 Downloading & installing the application «Smart Life»

About the Smart Life app:

You'll need to create a «Smart Life» account to control your heat pump remotely.

The «Smart Life» app lets you control your home appliances from anywhere. You can add and control multiple devices at once.

- You can share your devices with other Smart Life accounts that you have set up.
- Receive real-time operational alerts.
- Create scenarios with several devices, depending on the app's weather data (geolocation required).

For more information, refer to the "Help" section of the "Smart Life" app.

The "Smart Life" app and services are provided by Hangzhou Tuya Technology. The company Poolstar, owner and distributor of the Poolex brand, cannot be held responsible for the operation of the "Smart Life" application.

The company Poolstar has no access to your "Smart Life" account.

We're presenting the "Smart Life" application because it's the one we use for our tests, but you can also choose an equivalent application, such as "Tuya Smart".

iOS :

Scan or search for «Smart Life» in the App Store to download the app:



Check the compatibility of your phone and the version of your OS before installing the application.

Android :

Scan or search for «Smart Life» in the play to download the app:



Check the compatibility of your phone and the version of your OS before installing the application.

6. USE VIA MOBILE APPLICATION

6.2 Setting up the application



WARNING : Before you begin, make sure you have downloaded the «Smart Life» app, connected to your local WiFi network, and that your heat pump is electrically powered and running.

You'll need to create a «Smart Life» account to control your heat pump remotely. If you already have a Smart Life account, please log in and go directly to step 3.

Step 1: Click on «**Create new account**» and choose to register by «**Email**» or «**Phone**,» where a verification code will be sent to you.

Enter your email address or phone number and click «**Send verification code**».

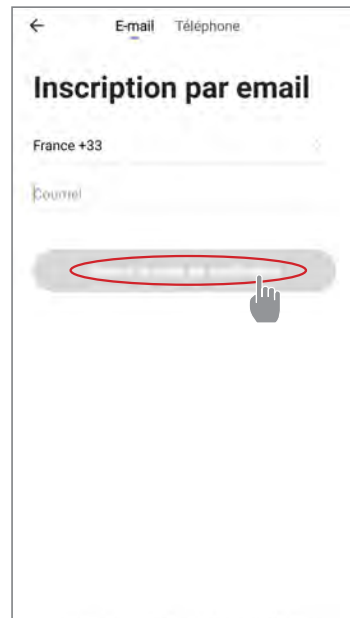
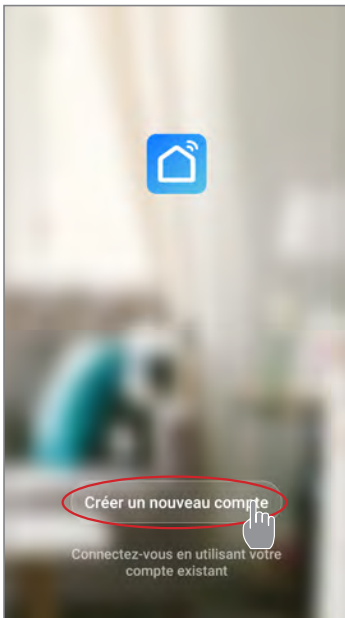

Step 2: Enter the verification code received by email or phone to validate your account.

Congratulations, you now belong to the “Smart Life” community.

6. USE VIA MOBILE APPLICATION

Step 3 (recommended): Add an object by clicking “...” and then “Add Object”. Enter a name («Pool» for example), then click “Done”.

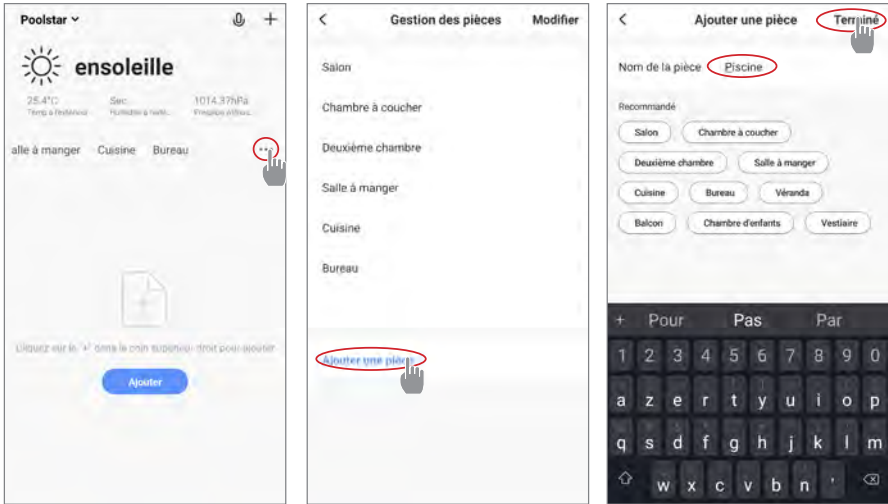

Step 4: Now add a device to your “Pool”.

Click “Add” or “+” and then “Large appliances...” followed by “Water heater”.

At this point, leave your smartphone on the “Add” screen and go to the pairing step for your control box.

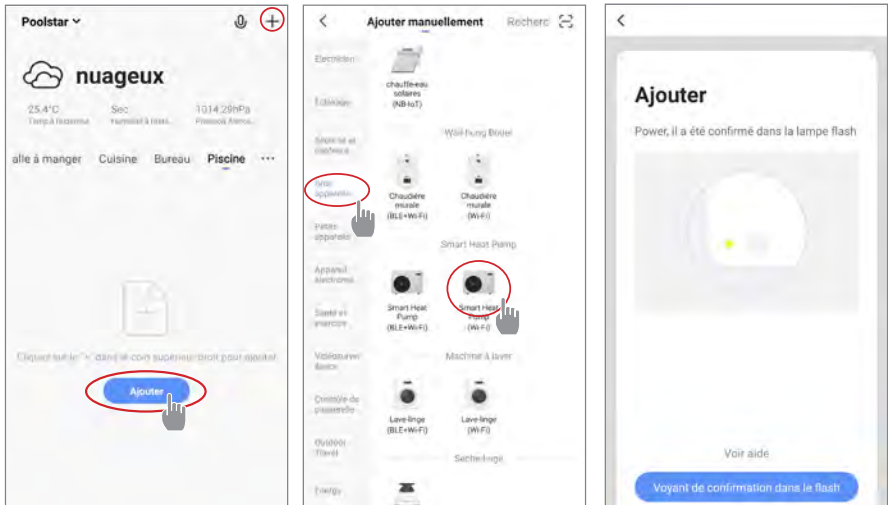

6. USE VIA MOBILE APPLICATION

6.3 Pairing the heat pump

Step 1: Now start the pairing.

Choose your home WiFi network, enter the WiFi password and press "Confirm".



WARNING : The «Smart Life» application only supports 2.4Ghz WiFi networks.

If your WiFi network uses the 5GHz frequency, go to the interface of your home WiFi network to create a second 2.4GHz WiFi network (available for most Internet boxes, routers and WiFi access points).

Step 2: Activate the pairing mode on your heat pump.

To do this, see "Activate wifi", page 15.

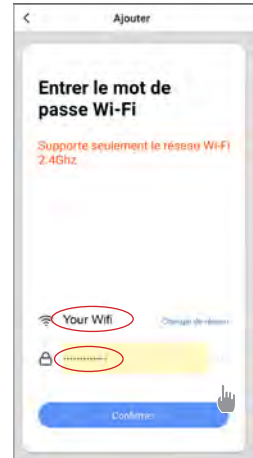

If there is a pairing problem, or if the heat pump is out of range of your wifi, you will need to use a wifi amplifier or relay (not supplied).

The pairing is successful, you can rename your Poolex heat pump then press "Done".

Congratulations, your heat pump can now be controlled from your smartphone.

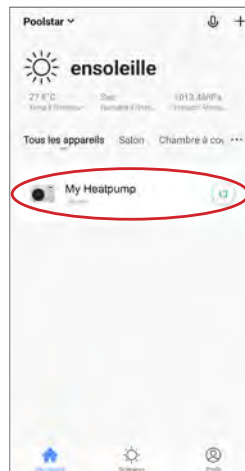
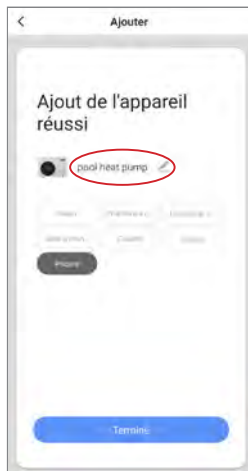

6. USE VIA MOBILE APPLICATION

6.4 Controlling

1. User interface

- 1 Current pool temperature
- 2 Temperature set point
- 3 Current operating mode
- 4 Switch the heat pump on/off
- 5 Change the temperature
- 6 Change operating mode
- 7 Set the operating range

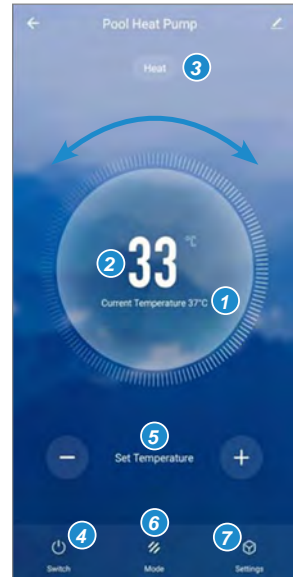

2. Heat pump operating mode selector

You can choose between Auto, Heating or Cooling modes.

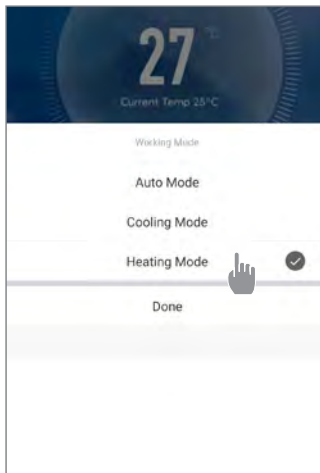

Available modes

- Automatic
- Cooling
- Heating

6. USE VIA MOBILE APPLICATION

3. About the settings

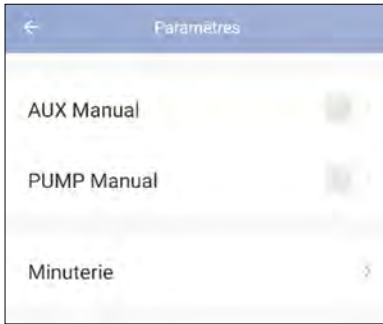

Activating the manual mode (or automatic) for the SPA heater

Activating the manual mode (or automatic) for the optional pump

Timer

4. Setting up the heat pump operating range

Step 1: Create a time schedule, choose the time, the day(s) of the week concerned, and the action (switch on or switch off), then save.

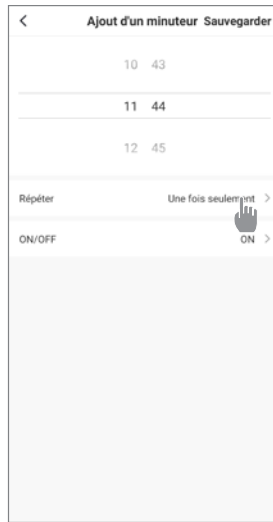
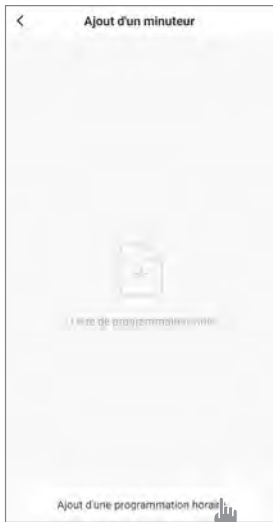

Step 2: To delete a time slot, press and hold the time slot.

7. MAINTENANCE AND REPAIRS

7.1 Maintenance, servicing and winterizing



WARNING: Before undertaking maintenance work on the unit, ensure that you have disconnected the electrical power supply.

Cleaning

The heat pump housing must be cleaned with a damp cloth. Using detergents or other household cleaning products may degrade the surface of the housing and affect its integrity.

The evaporator at the rear of the heat pump must be carefully cleaned with a vacuum cleaner and soft brush attachment.

Annual maintenance

The following operations must be undertaken by a qualified person at least once a year.

- Carry out safety checks.
- Check the integrity of the electrical wiring.
- Check the earthing connections.

Wintering

Your heat pump is designed to operate in all weather. However, if you winterize your SPA, it is not recommended to leave the heat pump outside for long periods of time (eg over winter). After draining down the SPA for the winter, uninstall the heat pump and store it in a dry place.

7.2 Checking refrigerant pressure

The gauge is for monitoring the pressure of the refrigerant contained in the heat pump.

The values it indicates can vary considerably, depending on the climate, temperature and atmospheric pressure.

When the heat pump is in operation:

The gauge's needle indicates the refrigerant pressure.

Mean operating range between 250 and 400 PSI (or about 1.7 to 2.7 MPa), depending on the ambient temperature and atmospheric pressure.

When the heat pump is shut down:

The needle indicates the same value as the ambient temperature (within a few degrees) and the corresponding atmospheric pressure (between 150 and 350 PSI maximum, or about 1 to 2.4 MPa).

If left unused for a long period of time:

Check the pressure gauge before starting up the heat pump. It must indicate at least 80 PSI (or about 0.6 MPa).



If the pressure goes down too much, the heat pump will display an error message and automatically go into 'safe' mode.

This means that there has been a leakage of refrigerant and that you must call a qualified technician to replace it.

7. MAINTENANCE AND REPAIRS



Under normal conditions, a suitable heat pump can heat up the tub water by 1°C to 2°C per hour. It is therefore normal that you do not feel any difference in temperature at the outlet level when the heat pump is on.

A heated tub must be covered and insulated to avoid any heat loss.

7.3 Breakdown and faults

In the event of a problem, the heat pump's screen displays an error code instead of temperature indications. Please consult the table below to find the possible causes of a fault and the actions to be taken.

Code	Anomaly detected	Resolution
E01	Discharge temperature failed	Check the water flow
E05	Coil temperature failed	Check the temperature sensor
E09	Suction temperature failed	Check the temperature sensor
E19	Water inlet temperature failed	Check the temperature sensor
E21	Controller communication failed	<ol style="list-style-type: none">1. Check the wire connection2. Replace the controller3. Replace main PCB
E22	Ambient temperature failed	Check the temperature sensor
E25	Water flow switch failed	Check the water flow
E27	Communication failed between PCB and compressor driver	<ol style="list-style-type: none">1. Check the wire connection2. Replace outdoor PCB3. Replace the compressor driver
E28	EEPROM communication failed	<ol style="list-style-type: none">1. Check the wire connection2. Replace EEPROM3. Replace the controller
S06	Low voltage protection	<ol style="list-style-type: none">1. Check the fan motor2. Check the water flow3. Check if the EEV is open
S11	Discharge temperature too high protection	<ol style="list-style-type: none">1. Check the temperature sensor2. Check if the fan motor is working correctly when cooling3. Check the throttling
S25	Ambient temperature too low protection	<ol style="list-style-type: none">1. Check if any resist around the heat pump2. Check the water flow when cooling
S27	Coil temperature too high protection	<ol style="list-style-type: none">1. Check the fan motor2. Check for barriers around the evaporator

7. MAINTENANCE AND REPAIRS

Code	Anomaly detected	Resolution
r01	Compressor over current	<ol style="list-style-type: none"> 1. Check the input voltage 2. Check the water flow 3. Check the throttling 4. Check the heat exchange around the heat pump
r02	Compressor startup failed	Check input voltage
r03	DC fan motor A failed	<ol style="list-style-type: none"> 1. Check the wire connection of fan motor 2. Check if any block of fan motor
r04	DC fan motor B failed	<ol style="list-style-type: none"> 1. Check the wire connection of fan motor 2. Check if any block of fan motor
r05	IPM overheat shut down	<ol style="list-style-type: none"> 1. Check the fan motor 2. Replace IPM board/compressor driver
r06	AC input current too high	Check input power supply
r08	PCB communication failed	<ol style="list-style-type: none"> 1. Check the wire connection 2. Replace PCB 3. Replace compressor driver
r10	DC bus overvoltage	Check input power supply
r11	DC bus undervoltage	Check input power supply
r12	AC input overvoltage failed	Check input power supply
r13	AC input undervoltage failed	Check input power supply
r16	EEPROM failed	<ol style="list-style-type: none"> 1. Replace main PCB 2. Update the software
r23	Compressor phase loss	<ol style="list-style-type: none"> 1. Check the input power supply 2. Check the wire connection
r25	Current sampling signal overcurrent (hardware overcurrent)	<ol style="list-style-type: none"> 1. Check input power supply 2. Check if any resist around the heat pump 3. Check the water flow

Other problem



The spa filtration pump is running continuously.

- » Check the filtration time setting on the spa control box and adjust if necessary.

Tip: Minimum filtration time for an indoor spa is 5 hours, for an outdoor spa 8 hours.

- » However, if you wish to reduce this circulation time, adjust the temperature on the spa control box to the same set temperature as on the heat pump.

8. WARRANTY

8.1 General terms and conditions of warranty

Poolstar guarantees the original owner against material defects and manufacturing defects of Poolx heat pump ICE SPA for a period of **three (3) years**.

The compressor is guaranteed for a period of **seven (7) years**. The titanium coil is guaranteed against corrosion for a period of **fifteen (15) years**.

The warranty enters into force on the first billing date.

This warranty does not apply to the following situations:

- Malfunction or damage resulting from installation, use or repair that does not comply with the safety instructions.
- Malfunction or damage deriving from an unsuitable chemical environment of the swimming pool.
- Malfunction or damage resulting from conditions unsuitable for the intended use of the device.
- Damage resulting from negligence, accident, or force majeure.
- Malfunction or damage deriving from the use of unauthorized accessories.

Repairs undertaken during the warranty period must be approved before being carried out by a qualified technician. This warranty is void in the event of repairs to the device made by individuals which have not been authorised by Poolstar.

The parts under warranty shall be replaced or repaired at the discretion of Poolstar. Faulty parts must be returned to us during the warranty period in order to be covered. The warranty does not cover unauthorized labor or replacement costs. Delivery costs for returning the faulty part are not covered by the warranty.

Dear customer,

A question? A problem? Or simply register your warranty, find us on our website:

<https://assistance.poolstar.fr/>

Thank you for your trust and support. Happy bathing!

Your personal information is processed in accordance with the French Data Protection Act of 06 January 1978 and will not be shared with 3rd parties.

A. ANNEXE / APÉNDICE / APPENDICE / APPENDIX / ANHANG / BIJLAGE

A.1. Schéma électrique / Diagrama de cableado / Schema elettrico / Wiring diagram / Stromlaufplan / Elektrisch schema

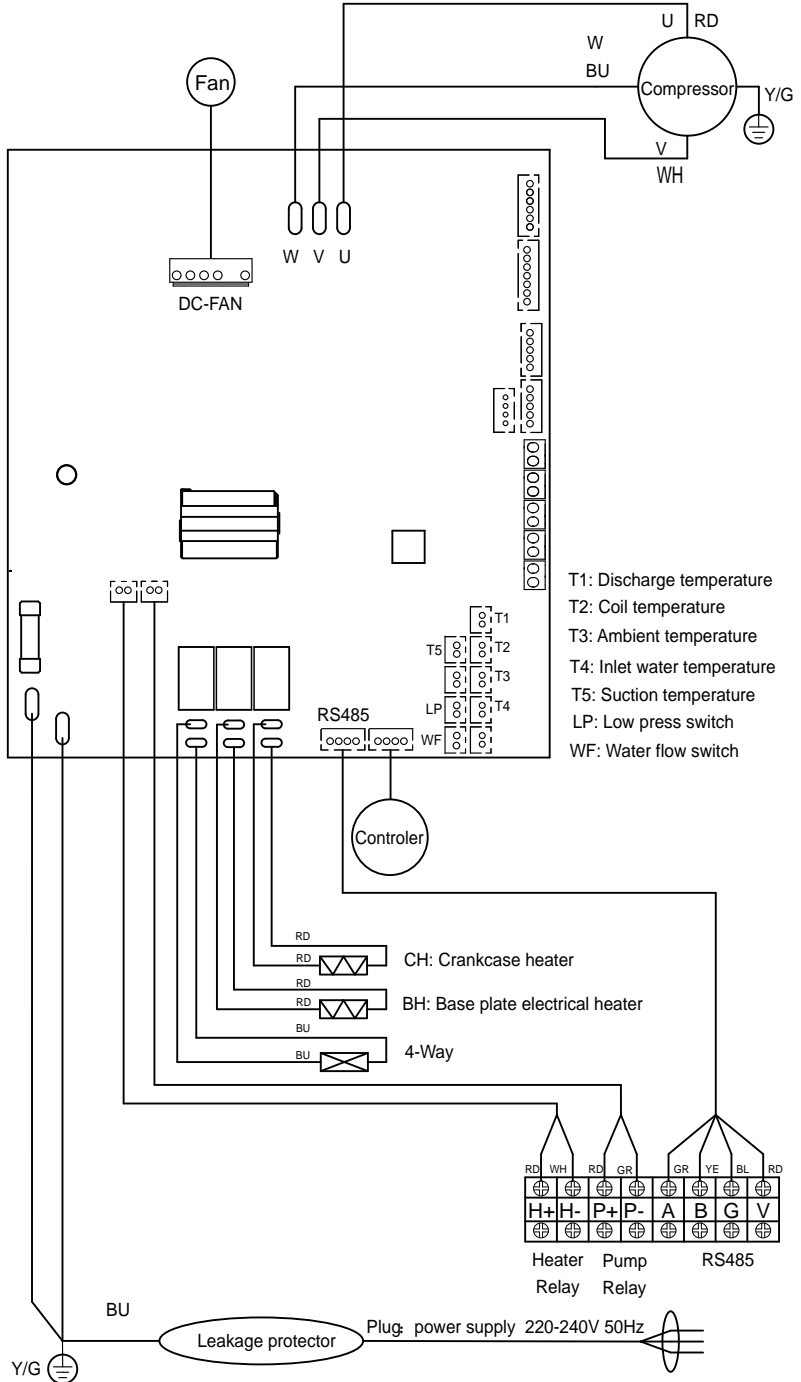

POOLEX

ICE SPA

ASSISTANCE TECHNIQUE

www.poolex.fr



03-2024

CE